

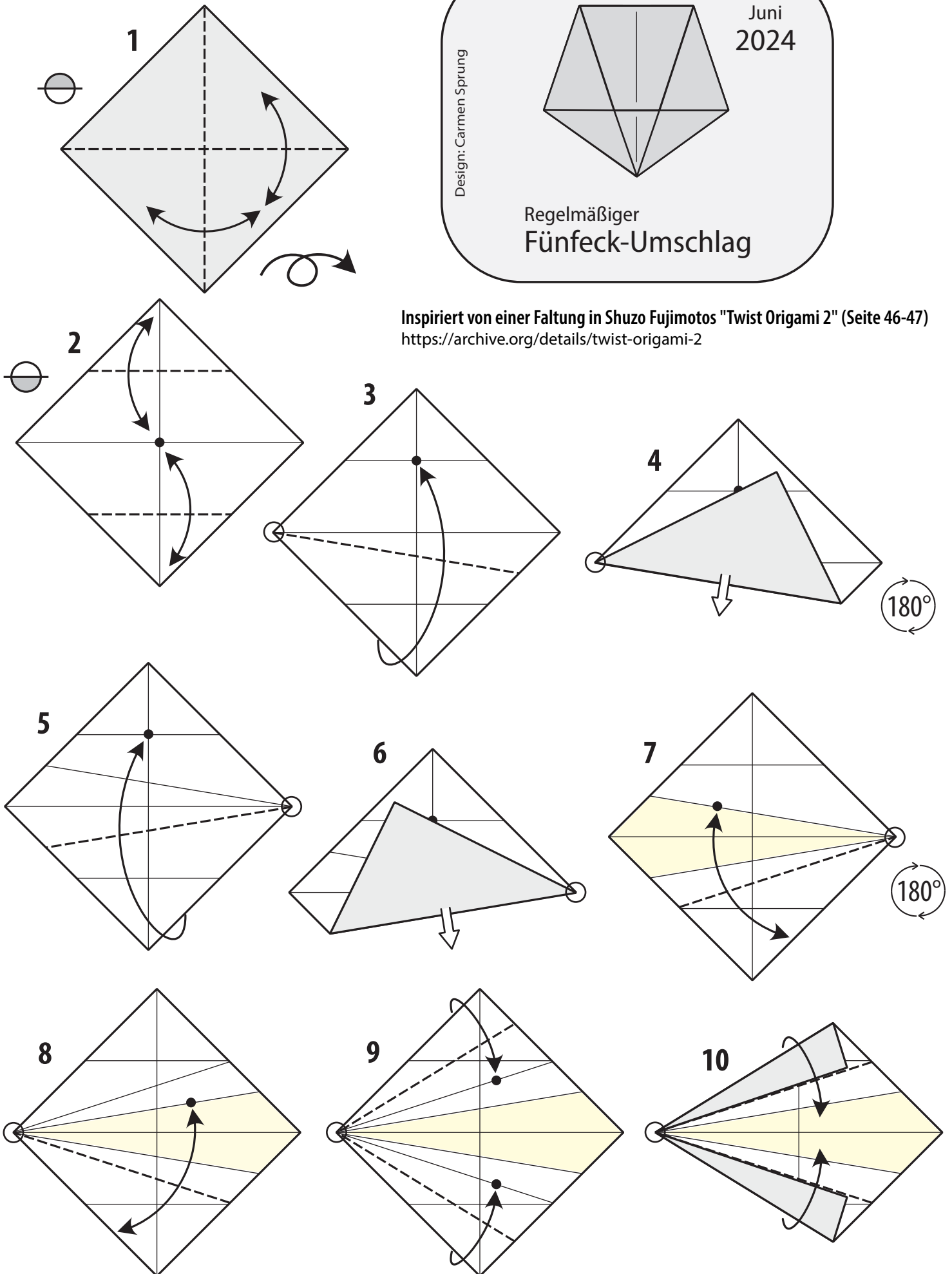

Inspired by a fold in Shuzo Fujimoto's "Twist Origami 2" (Seite 46-47)
<https://archive.org/details/twist-origami-2>

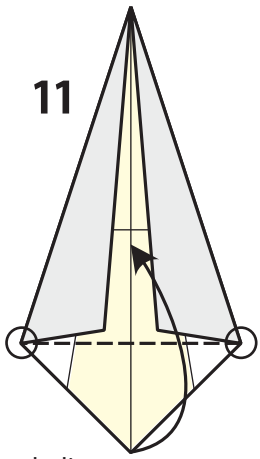



Durch die gekennzeichneten Eckpunkte falten.

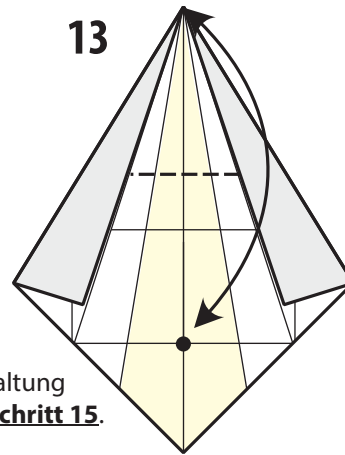
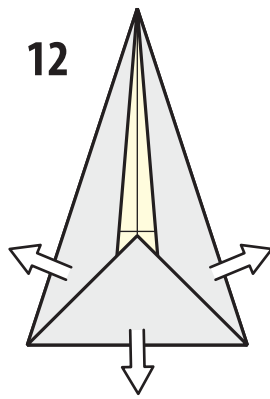

Vorfaltung für **Schritt 15**.

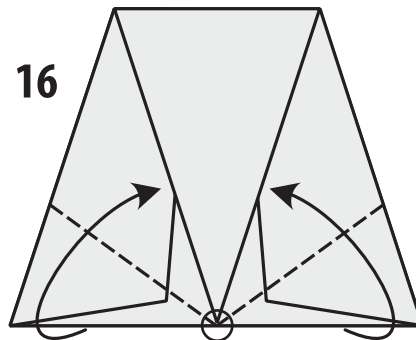
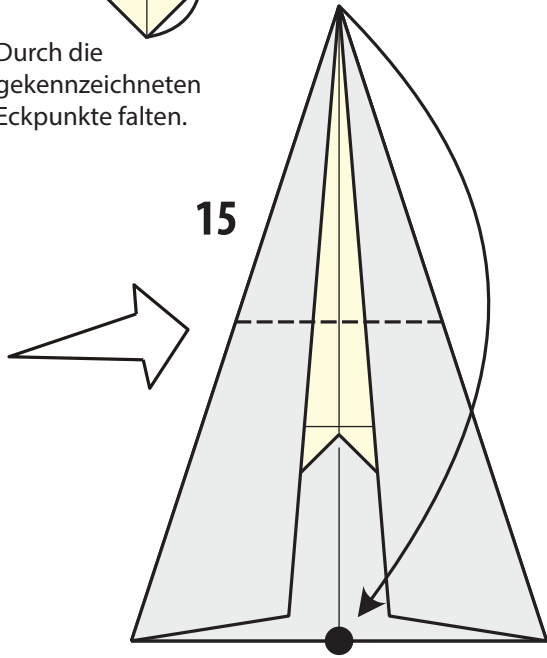
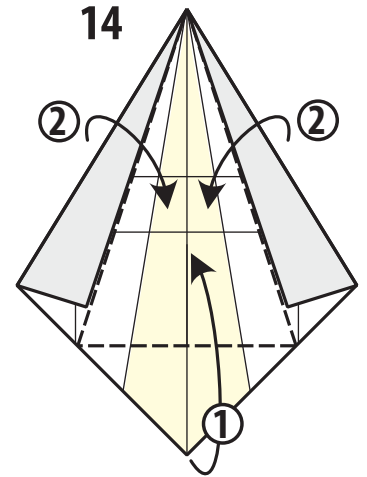

Vorfaltung für **Schritt 18**.

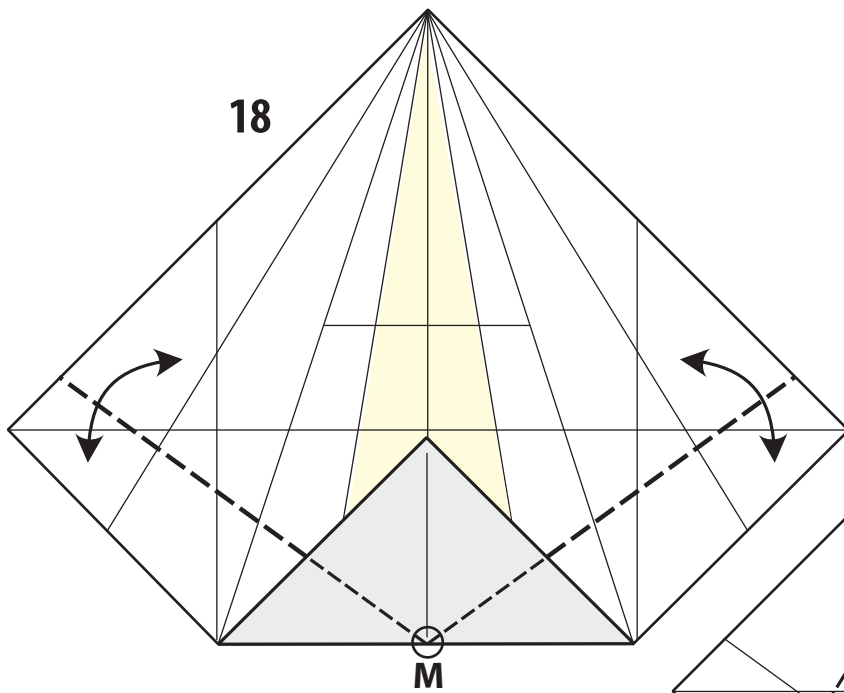
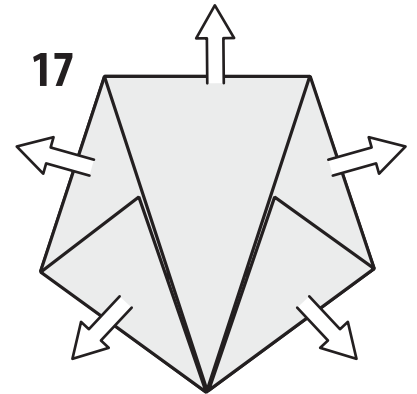

Die Falten, die bereits durch den Punkt **M** gehen, nach rechts und links verlängern.

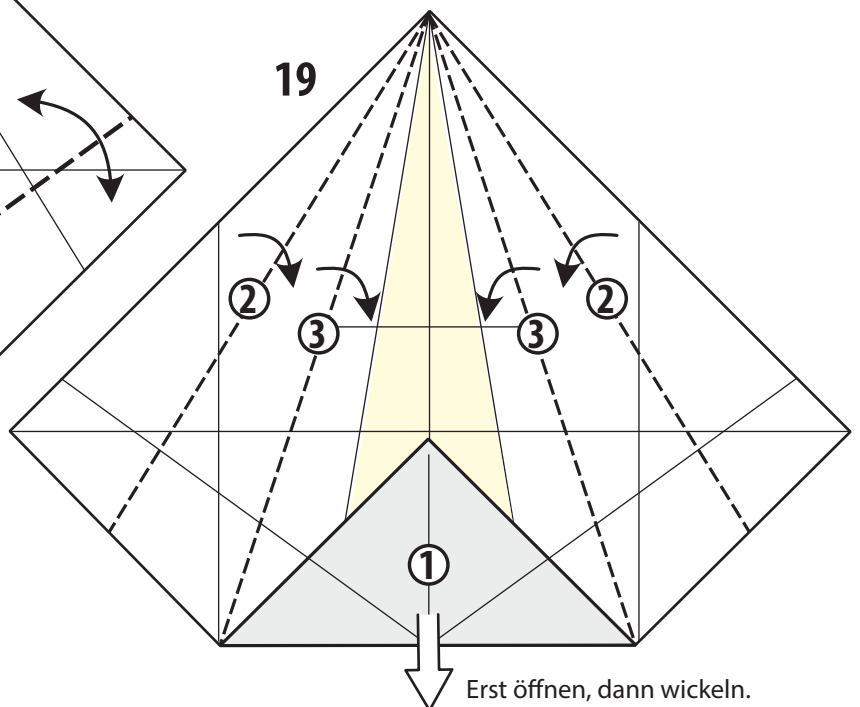

Erst öffnen, dann wickeln.

20

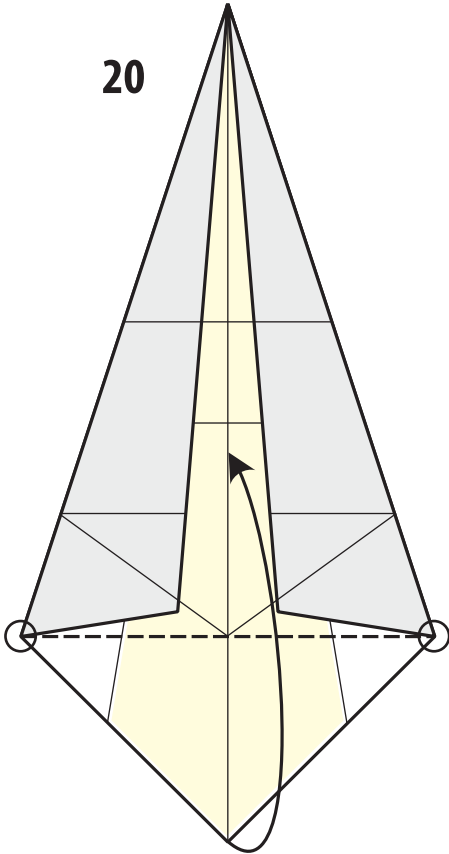

21

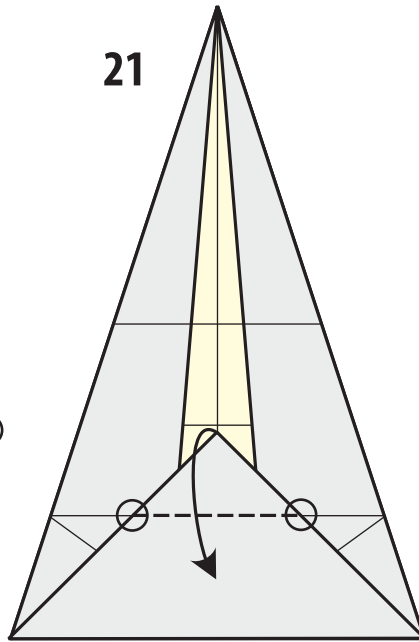

22

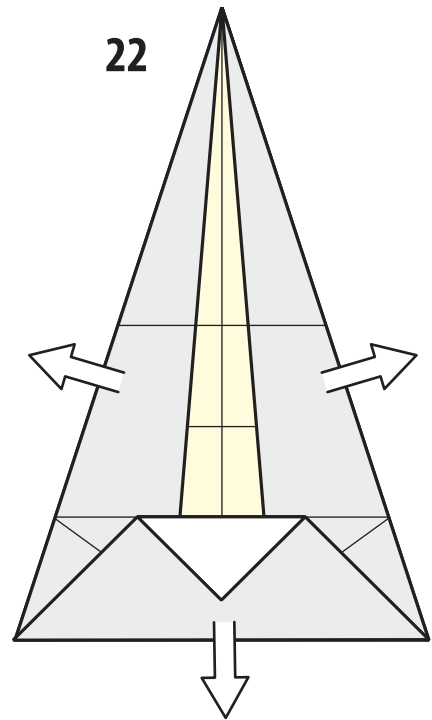

Bei dieser Faltung an den horizontalen Faltnien rechts und links orientieren.

Ganz öffnen.

23

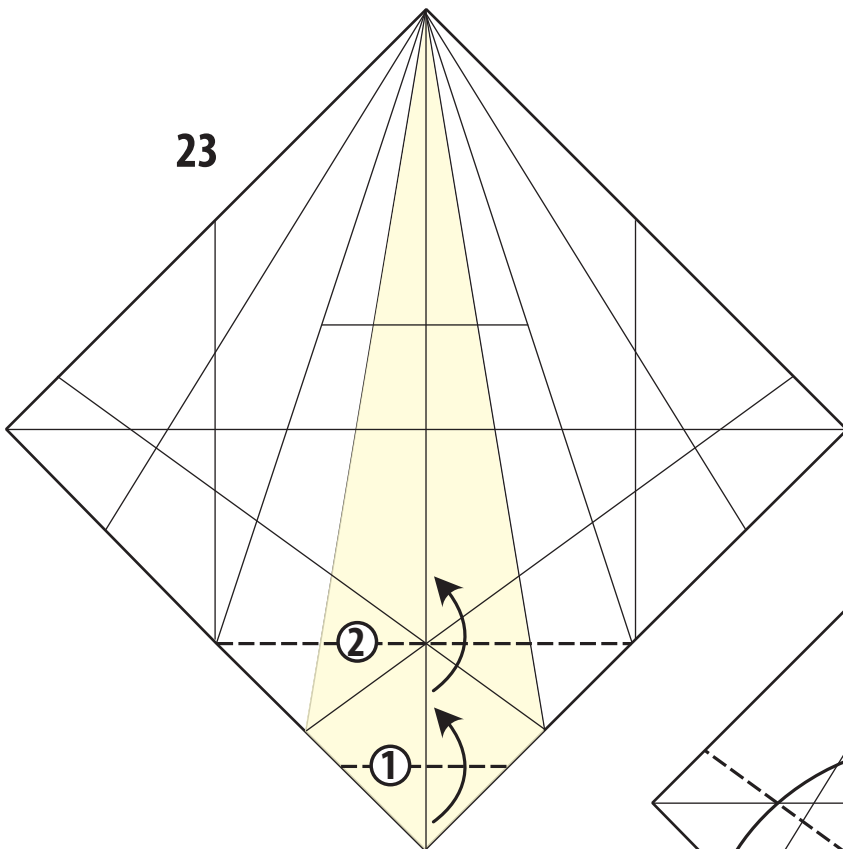

Wickeln.

24

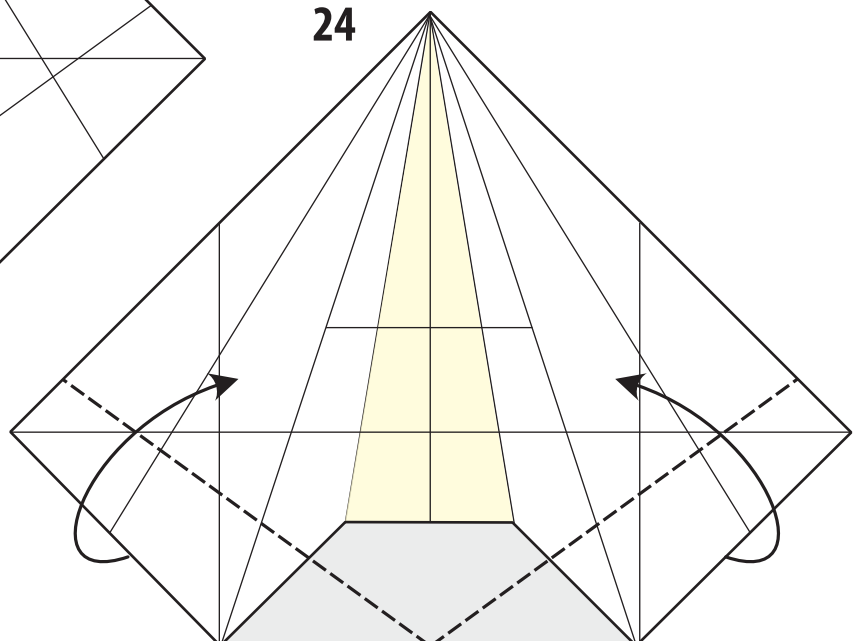

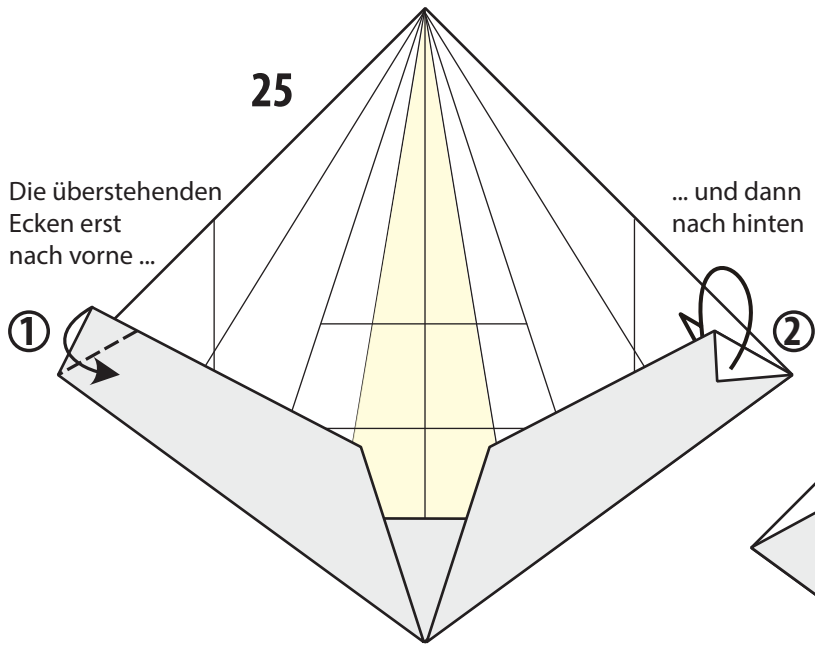

... und dann nach hinten falten.

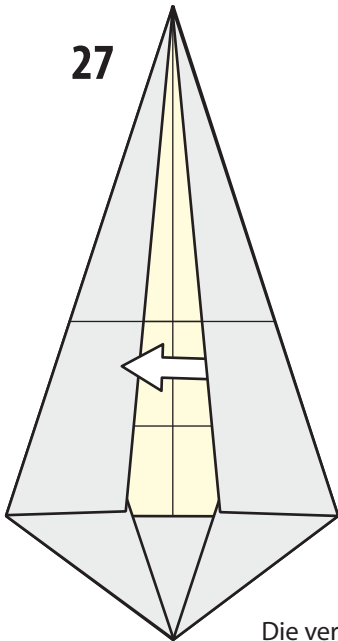
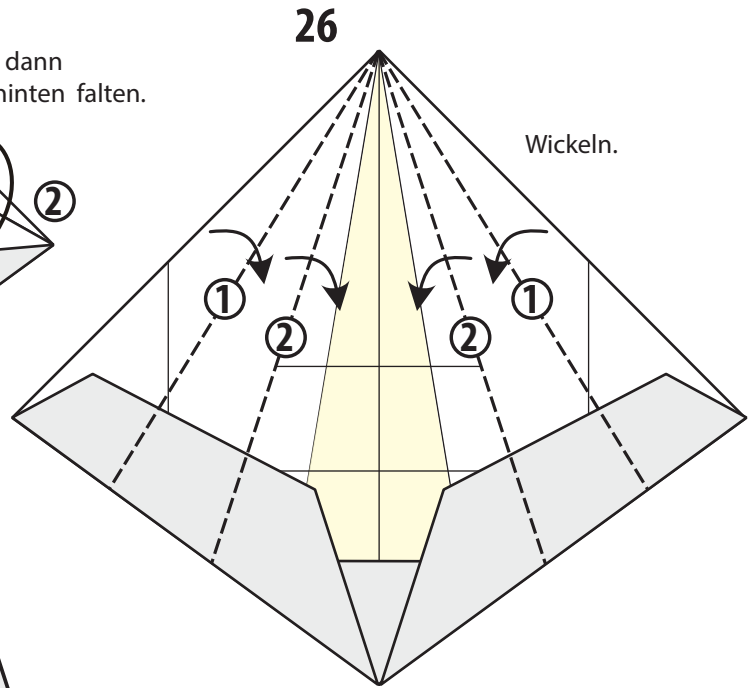

Die verdeckte Papierlage herausholen und dann um die darunter liegende Kante wickeln.

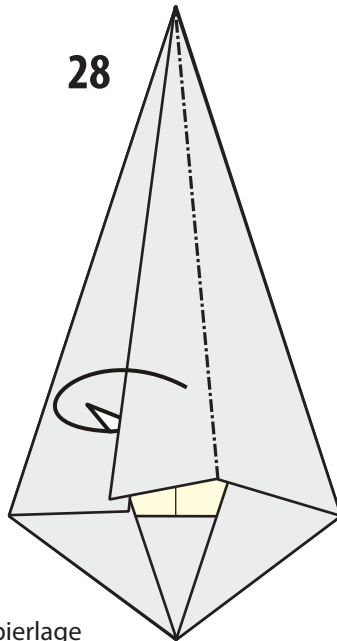

Schritt 27-28 wiederholen.

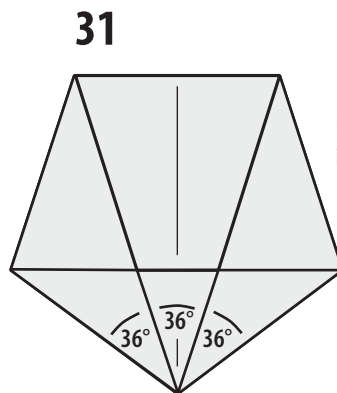
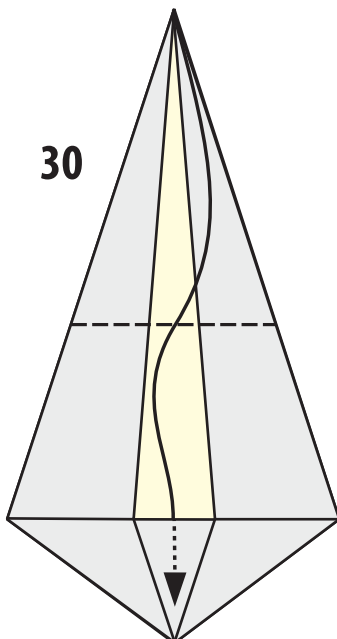
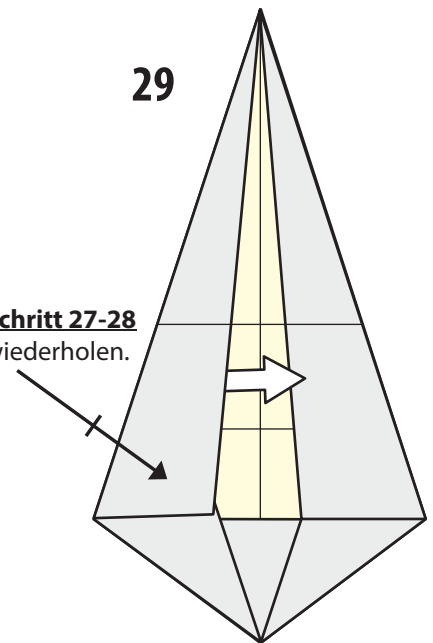

Ein regelmäßiger Fünfeck-Umschlag ist entstanden.

ENDE
Juni
2024